

# MANISCOPIC

# MRT 2145

*M Series*



- Lift height : 20.60 m
- Max. reach : 17.00 m
- Engine : 123 HP - 91 kw
- 4 wheel drive - 4 wheel steer
- Hydrostatic transmission
- Levelling system



**ROTATION ON STABILISERS FULLY EXTENDED WITH FORKS**

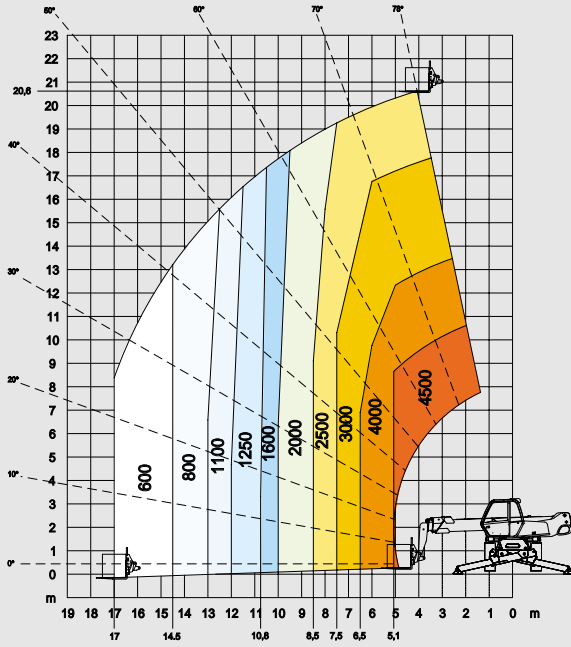

**FRONTAL POSITION ON WHEELS WITH FORKS**

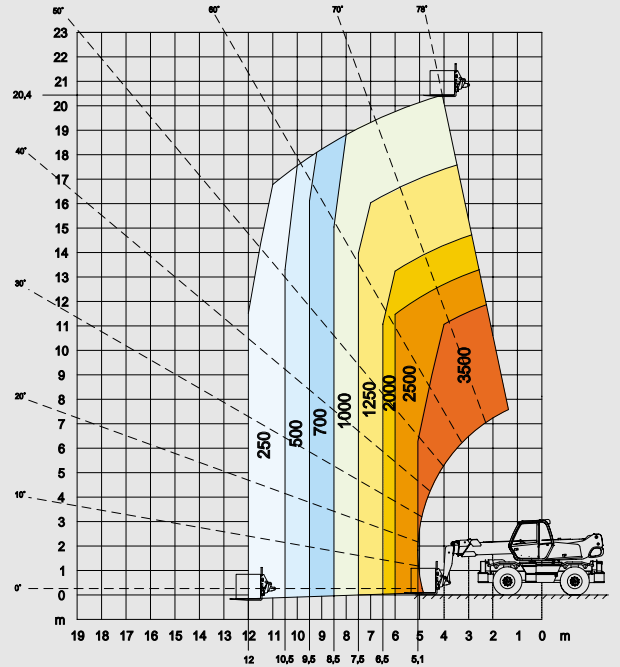

**ROTATION ON STABILISERS NOT FULLY EXTENDED WITH FORKS**

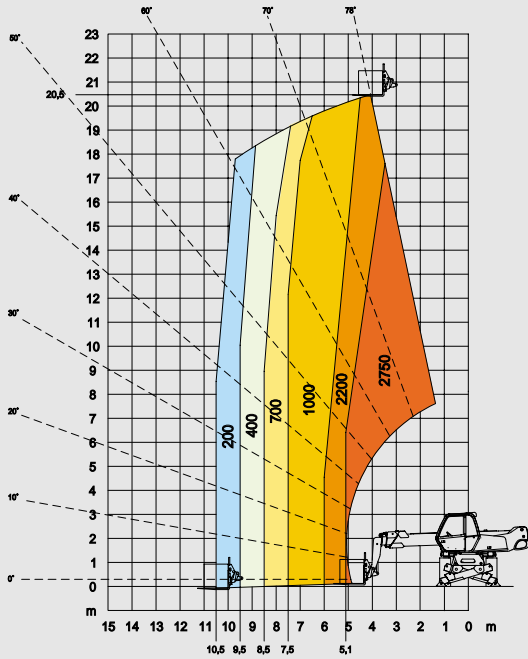

**ROTATION ON STABILISERS FULLY EXTENDED WITH 5T WINCH**

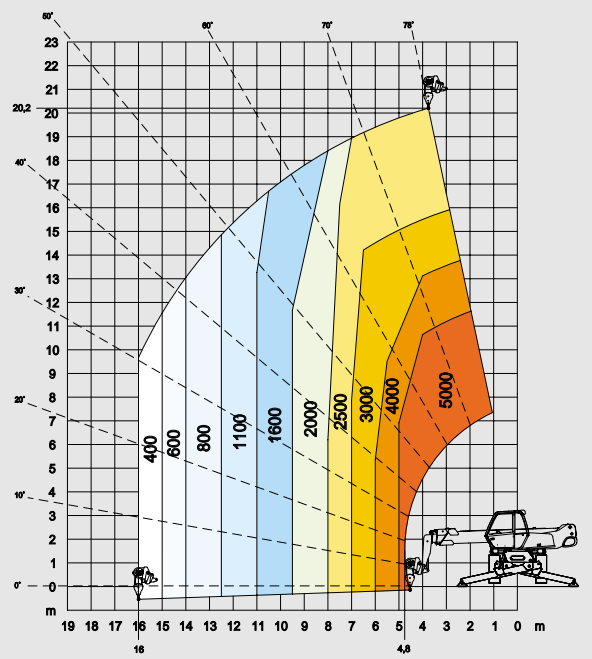

**ROTATION ON STABILISERS FULLY EXTENDED WITH JIB P 600**

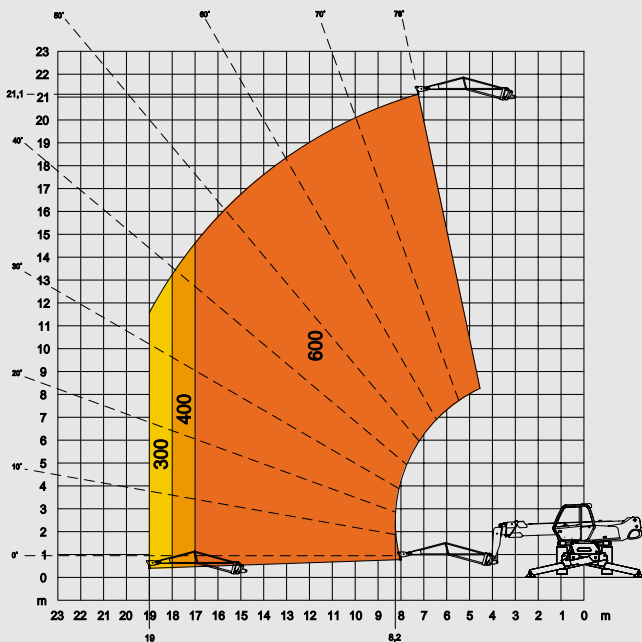

**ROTATION ON STABILISERS FULLY EXTENDED WITH JIB P 1500**

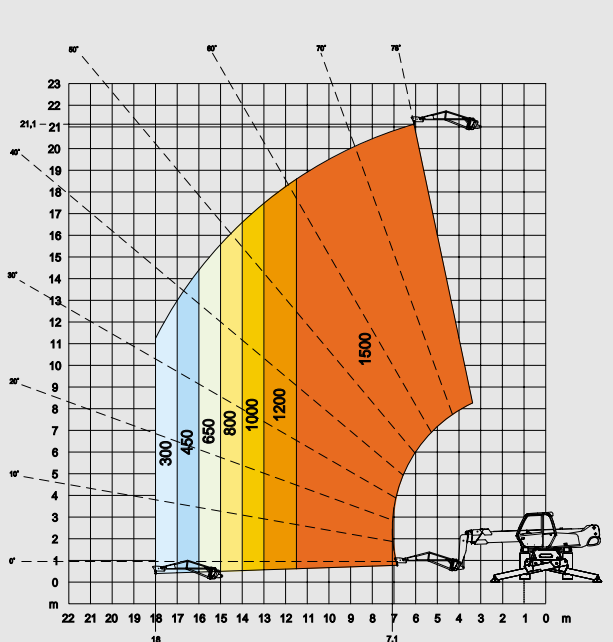

MRT 2145 M Series

**ROTATION ON STABILISERS FULLY EXTENDED  
WITH EXTENSIBLE PLATFORM 2,25/ 4 m**

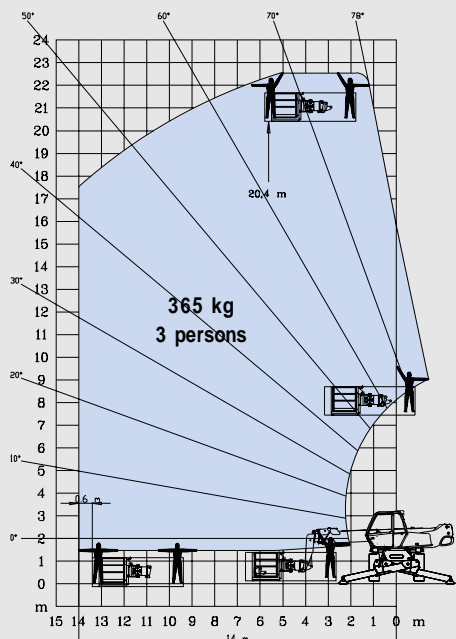

**ROTATION ON STABILISERS FULLY EXTENDED  
WITH 1000 KG PLATFORM 2,25/ 4 m**

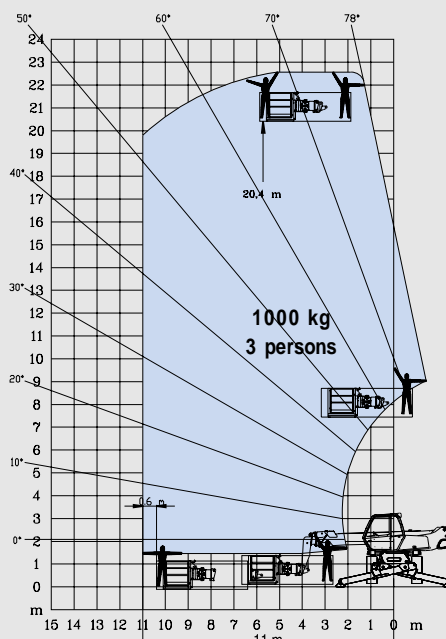

**ROTATION ON STABILISERS FULLY EXTENDED  
WITH 3 D SYSTEM IN POSITIVE POSITION**

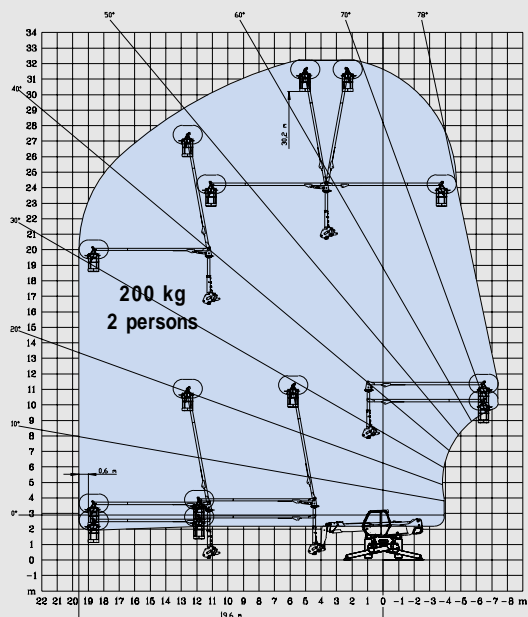

**ROTATION ON STABILISERS FULLY EXTENDED  
WITH 3 D SYSTEM IN NEGATIVE POSITION**

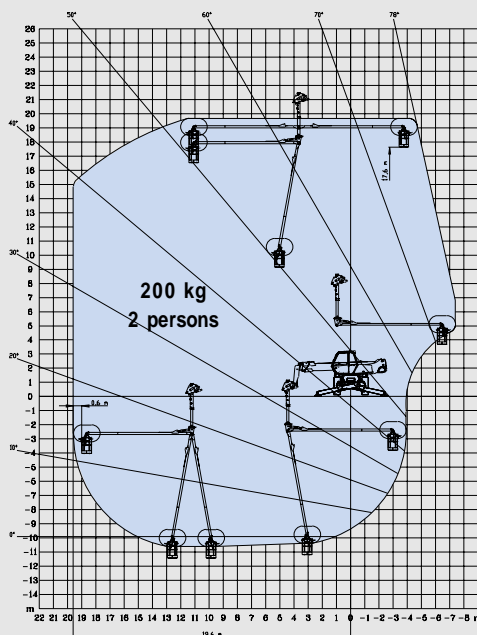

**ROTATION ON STABILISERS FULLY EXTENDED  
WITH AERIAL JIB PLATFORM**

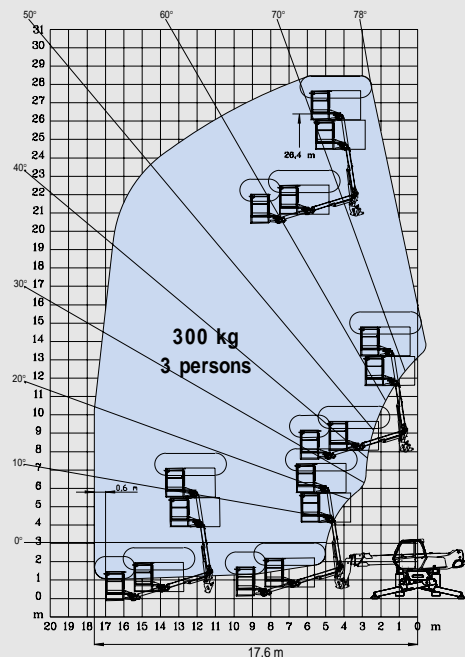

**ROTATION ON STABILISERS FULLY EXTENDED  
WITH CRANE JIB**

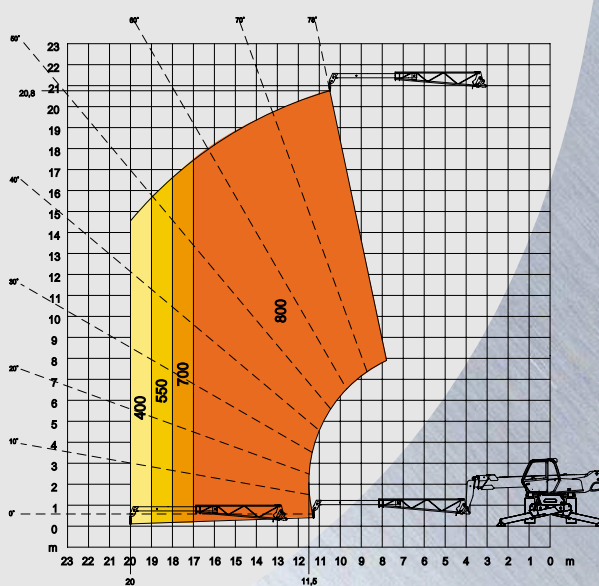

## MRT 2145 *M Series*



**Lift capacity** (on stabilisers).....4500 kg  
at 500 mm from forks heels



**Lift height** : .....20.60 m



**Tyres**  
18 - 22,5



**Forks (mm)**  
Length .....1200  
Width x thickness .....150 X 50



**Multidisc brakes** : hydraulically assisted on both axles  
Negative parking brake



**Engine PERKINS**  
Type .....1004.40 TW  
Capacity .....4 cyl. 3990 cm<sup>3</sup>  
Power (ISO/ TR 14396).....123 HP/91 kw  
at 2300 rpm  
Water cooling  
Direct injection



**Transmission** .....hydrostatic  
With automatic power regulation (hydraulic variable  
displacement pump and motor)  
Reversing shift.....electromagnetic  
2 speed forward and reverse  
Travel speed.....25 km/h



**Rear axle**  
**Frame levelling on front axle +/- 8° (15%)**  
Automatic rear axle locking system  
over 15 ° rotation

**4 stabilisers**  
simultaneous or individually controlled



**Total and continuous rotation**  
Turret mounted on a double slew ring  
Hydraulic and electric rotation



**Hydraulics**  
3 pumps gear type .....270 bars/160 l/min



**Control** : 2 electro proportional control joysticks for all  
hydraulic movements



**Capacities**  
Cooling system.....15 l.  
Engine oil .....11.5 l.  
Hydraulic oil.....200 l.  
Fuel tank .....230 l.



**Weight unladen** (with forks) .....16650 kg  
**Overall width**.....2.43 m  
**Overall height**.....3.02 m  
**Overall length**.....6.78 m  
**Ground clearance**.....0.37 m  
**Drawbar pull**.....10800 daN



**Standard load moment indicator**  
(mobile crane standards)

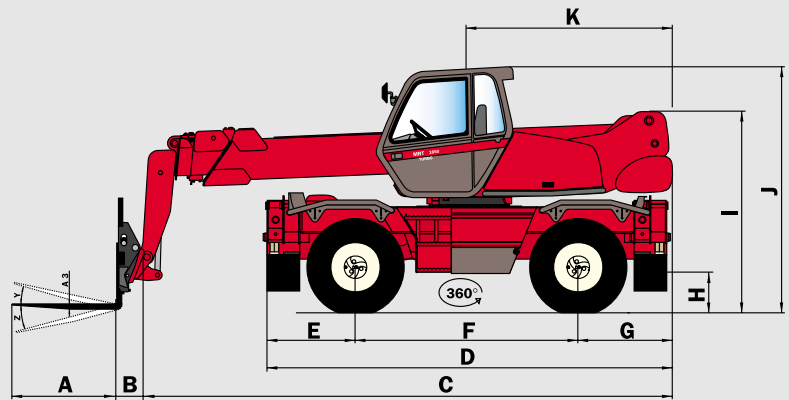

A	1200
A1	150
A2	1320
A3	60
B	290
C	6490
D	5050
E	1155
F	2750
G	1155
H	370
I	2420
J	3025
K	2485
L	1930
M	2425
N	4700
O	5100
P	200
Q	4500
R	3800
S	4550
V	950
Y	12°
Z	105°

mm

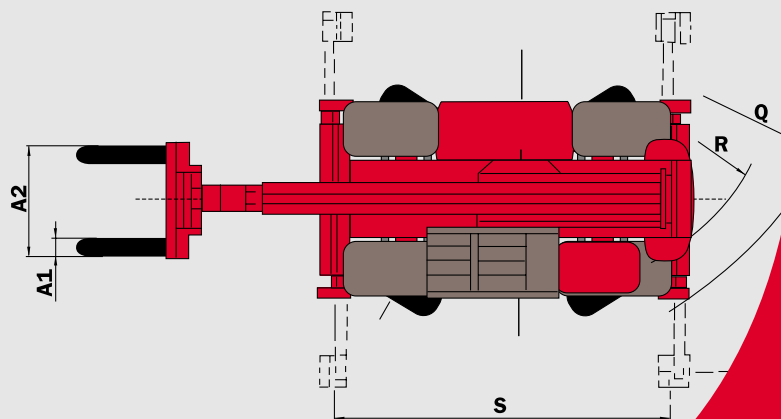
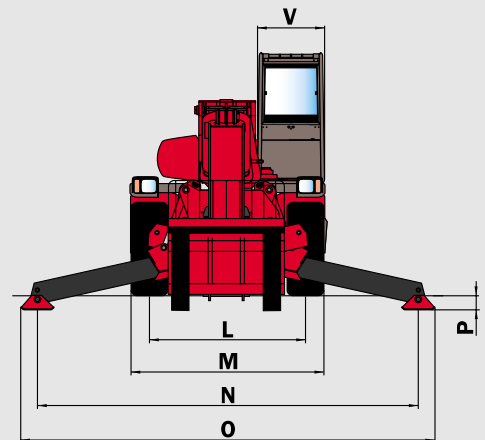

This publication in no way constitutes an offer and the company reserves the right to alter specification without prior notice.  
The MANITOU models presented in this brochure can be supplied complete with optional equipment attachments.

